



09 00 00
GENERAL FINISHES REQUIREMENTS

1. GENERAL

A. Related sections:

- i. 00 00 13 – Designing Learning Environments
- ii. 01 35 46 – Indoor Air Quality Procedures – During Construction
- iii. 01 41 26.06 – Dining Services
- iv. 09 30 00 – Tiling
- v. 09 60 00 – Flooring
- vi. 09 68 00 – Carpeting
- vii. 09 70 00 – Wall Finishes
- viii. 09 72 00 – Wall Coverings
- ix. 09 80 00 – Acoustical Treatment
- x. 09 91 23 – Interior Painting

B. Designing Learning Environments

- i. Low-maintenance finishes are preferred in classroom spaces. Hard surface, resilient flooring, and / or carpeting may be used in classroom spaces, but should be determined on a case-by-case basis. Where a live acoustical environment is acceptable and / or desired, consider hard surface flooring with a lower noise reduction coefficient (NRC). Where a more controlled, sound absorptive space is desired, such as a distance learning classroom, consider carpet or flooring with a higher NRC. Ensure that floor finishes are durable, and properly protected to withstand the amount of traffic and abuse that will occur in each specific classroom. An example of proper floor finish protection would include providing durable stair nosing at steps in tiered classrooms.
- ii. Gypsum wallboard with either epoxy coatings or other durable materials is adequate for wall areas within arm's reach of end users. Wall finishes that have sound-absorbing qualities are acceptable in locations outside of arm's reach. Where acoustical wall panels must be provided within arm's reach, consider using "hard-side" panels that have a high-impact underlayment and chemically hardened edges. In either case, ensure that fabrics covering acoustical wall panels are acoustically transparent (Guilford of Maine Fabric FR701 or equal). Consider providing chair rails in areas with movable furnishings, and corner guards in high-traffic areas to protect walls from damage.
- iii. Typical drop ceiling panel materials, as well as gypsum wall board are acceptable finishes for classroom ceilings. Ceiling design should take into account ceiling mounted equipment locations and acoustical requirements.
- iv. Color and selection of all finishes are to be coordinated and approved by UGA. Design Professionals should keep the following considerations in mind when selecting finish colors:
 - a. A person's eyes move toward the brightest object in its field of vision. Thus, lighting should highlight what is most important to see. Desk surfaces should contrast from the paper, book, or computer screen. Also, the instructor wall, where markerboards and



projection screens are located, should be darker than surrounding walls.

- b. Consider light blues and grays finishes that are non-glare in classrooms where instructors are to be recorded.

The following are recommended rules of thumb¹ for surface reflectance values of classroom finishes:

Surface	Reflectance
Ceilings	80% or higher
Walls	50% to 70%
Floors	20% to 40%
Desktops	25% to 45 %

2. PRODUCTS

- A. Low volatile organic compound (VOC) materials shall be used within the interior weatherproofing of the facility; zero when available. Refer to Section 01 35 46 Indoor Air Quality – During Construction.
- B. **UGA Athens Campus Only** – The UGA FMD Building Services department implemented a Green Cleaning program for campus facilities in 2005. Design Professionals and Contractors shall specify and install products with finishes that can be successfully cleaned and maintained with the Green Cleaning program’s certified cleaning products. Acceptable Green Cleaning certified products are listed below. Exceptions as deemed appropriate by the Project Manager.
 - i. Acceptable manufactures are:
 - a. Designed For The Environment (DFE)
 - b. Eco Logo
 - c. Green Seal
 - ii. Acceptable chemical and waxing products are:
 - a. Green Solutions Floor Finish Remover (350504) – wax stripper
 - b. Green Solutions Floor Seal & Finish (350404) – wax / sealer
 - c. Green Solutions Grass Cleaner 102 – window cleaner
 - d. Peroxy Clean (003504) – general purpose cleaner
- C. All specified materials must have a demonstrated history in a similar institutional setting, with similar regularity of cleaning and maintenance, for at least five years.
- D. **FMD Projects only** – For animal rooms and other specialized locations, utilize a seamless polymer for the floor, wall, and lining systems.

3. EXECUTION

- A. Contractor shall include product cleaning requirements for all surfaces in the close out documents.

¹ Recommendations based on Illuminating Engineering Society of North America Standards 90.1 2013.



**Office of University Architects
for Facilities Planning**
UNIVERSITY OF GEORGIA

- B. Contractor shall completely remove all paint, epoxies, and other excess finish materials prior to completion of the Project. Additional unused supplies to be turned over to UGA shall be coordinated through the Project Manager at substantial completion.



09 00 00.01
CUSTODIAL STORAGE

1. GENERAL

- A. Related sections:
 - i. 09 00 00 – General Finishes Requirements
 - ii. 09 30 00 – Tiling
 - iii. 22 40 00 – Plumbing Fixtures
- B. Size:
 - i. The size of the custodial closet shall be large enough to store equipment and supplies with a minimum size of 5'-6" x 8'-0" and shall be the sole dedicated use of the room. See recommended layout at end of this section.
 - ii. If building requires large equipment and battery powered machines for maintenance, then the Custodial Storage room shall be larger than the minimum size of 5'-6" x 8'-0" and provide power outlets for charging and a service sink. Design Professional shall consult with Project Manager to determine if this is needed during programming and appropriate size.
- C. The walls shall be a light color.
- D. Floor surface options in order of preference by FMD:
 - i. Epoxied concrete
 - ii. Sealed concrete
 - iii. VCT or resilient tile
 - iv. Tile with nonporous grout. Refer to Section 09 30 00 Tiling.
- E. Service Sink
 - i. Refer to Section 22 40 00 Plumbing Fixtures, 2.B.xv. Service Sinks.
 - ii. It shall be accessible without emptying closet.
 - iii. The mop sink shall be floor mounted with a 24-inch tall stainless steel backsplash.
- F. Faucet
 - i. Refer to Section 22 40 00 Plumbing Fixtures, 2.B.xv. Service Sinks.
- G. Lighting
 - i. The light fixture lamps shall be protected by cage or diffuser.
- H. Shelving
 - i. There shall be two 12-inch x 48-inch shelves for chemicals.
 - ii. There shall be two 12-inch x 48-inch for supplies.
 - iii. There shall be adjustable brackets with 30-inch heavy duty standards.
 - iv. The height to the bottom shelf shall be 48 inches.
- I. Door
 - i. The door shall be a minimum of 36 inches wide and if code allows, swing out of the room.
 - ii. The custodial closet shall be individually keyed with access limited to FMD.
- J. Tool Holders and Mop Brackets
 - i. Shall be provided and installed by FMD after Material Completion.
 - ii. One tool holder shall be mounted over sink and preferably not over the faucet.
 - iii. One tool holder shall be mounted near door for brooms and dust mops.
 - iv. Mop brackets are mounted on 1 x 4 provided by FMD.

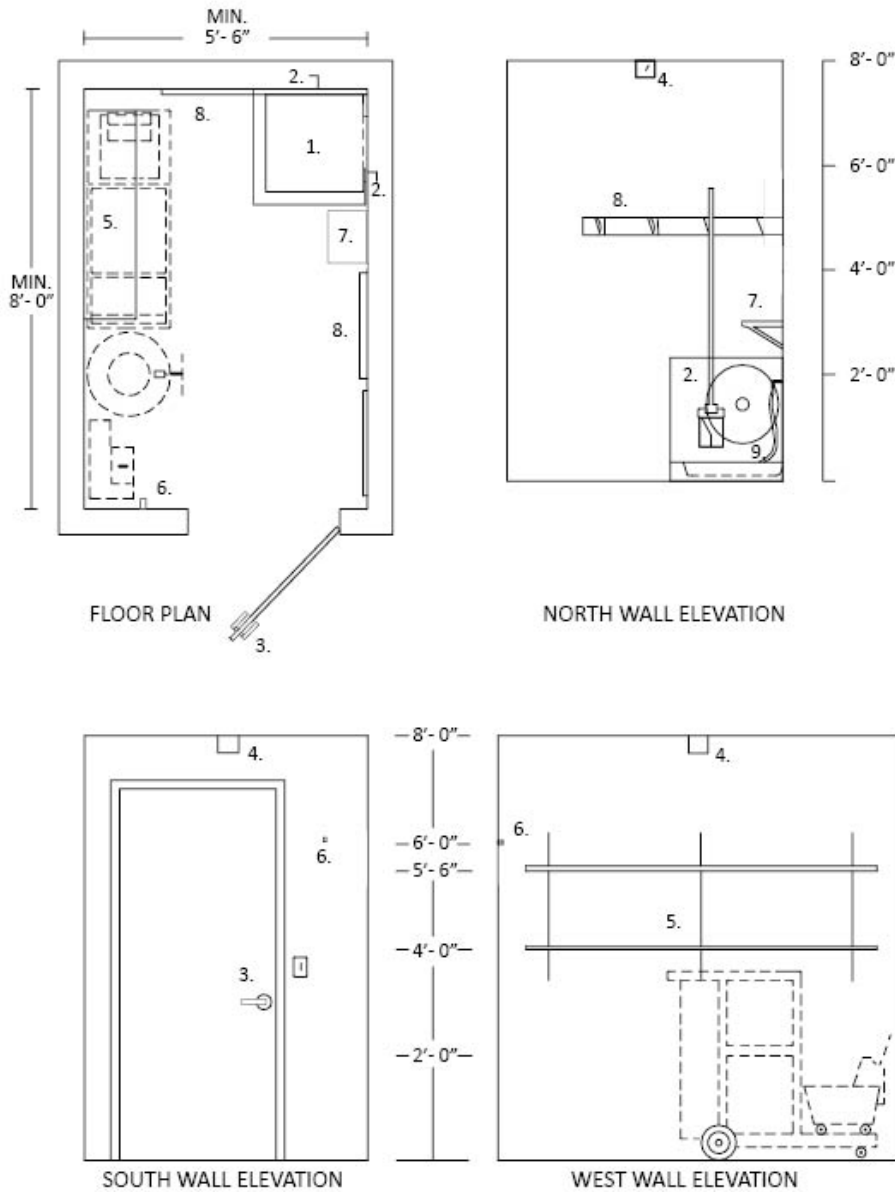

Custodial Storage Layout Legend

Contractor Furnished and Installed

1. Floor mounted sink
2. Stainless steel backsplash to 24 inches above floor sink
3. Individual keyed lock
4. Wire protector for light fixture if bare bulb is exposed
5. Adjustable shelves – 12 inches wide x 48 inches long
6. Coat hook

Owner Furnished and Owner Installed

7. Chemical Lock & Dial
8. "Gripit" tool holder
9. Hose – 36'



09 20 00
PLASTER & GYPSUM BOARD

1. **GENERAL**

A. Related sections:

- i. 01 35 46 – Indoor Air Quality Procedures – During Construction

2. **PRODUCTS**

- A. Low volatile organic compound (VOC) materials shall be used within the interior weatherproofing of the facility; zero when available. Refer to Section 01 35 46 Indoor Air Quality – During Construction.
- B. Regional Materials: Gypsum board shall have been manufactured within 500 miles of the project site. Provide documentation as requested by the Project Manager.
- C. Standard gypsum wall board product thickness is 5/8 inches. For typical wall assemblies, ½-inch gypsum board is prohibited.
- D. Wet areas and / or tile backer board:
 - i. Use cement backer board for tile.
 - ii. Paper-faced moisture resistant gypsum board panels (“green board”) are not allowed.
- E. Abuse resistant gypsum board and / or impact resistant gypsum board shall be considered for public areas, corridors, and student rooms. Design Professional shall coordinate with Project Manager.
- F. **For UGA Housing Only (New Construction)**
 - i. Abuse resistant, impact-resistant gypsum board for all public spaces, corridors, and student residential rooms.
 - ii. Joint treatment and wall finish shall be level 5 finish for all painted walls in accordance with the “Recommended Specification: Levels of Gypsum Board Finish” as published by the Gypsum Association and level 4 finish for all painted ceilings.
 - iii. Joint tape shall be paper tape as approved by abuse-resistant panel manufacturer.
 - iv. Corner reinforcement shall be galvanized steel with 1 ¼-inch wide fine expanded mesh flanges.

3. **EXECUTION**

- A. Install gypsum board only after building is enclosed.
- B. If plaster or gypsum board repairs that cause air borne dust are made as part of the punchlist corrections prior to Final Completion, the Contractor is responsible for full cleaning of areas that are affected by the plaster or gypsum board dust at no additional cost to the Owner. This includes cleaning of all affected surfaces like windows, furniture, carpets, etc. If final air filters were installed prior to any plaster or gypsum board punchlist corrections, Contractor is responsible for replacing air filters that serve affected areas again at no additional cost to the Owner.



09 30 00
TILING

1. GENERAL

- A. Related sections:
 - i. 01 35 46 – Indoor Air Quality Procedures – During Construction
 - ii. 09 00 00 – General Finishes Requirements
 - iii. 09 00 00.01 – Custodial Storage
- B. For public areas with high levels of pedestrian traffic, especially main entry lobbies and corridors, it is preferable to use a durable, low maintenance, long lasting floor material like granite.

2. PRODUCTS

- A. Low volatile organic compound (VOC) materials shall be used within the interior weatherproofing of the facility; zero when available. Refer to Section 01 35 46 Indoor Air Quality – During Construction.
- B. Regional Materials: See below for granite tile requirements. All other tile products shall have been extracted, harvested or recovered, as well as manufactured, within 500 miles of the project site for a minimum of 20%, based on cost, of the total materials value of flooring excluding granite tiling. Provide documentation as requested by the Project Manager.
- C. Silver Cloud Granite:
 - i. When the Project budget can afford granite flooring, the main field granite color shall be Silver Cloud (a granite with a marbling of grays and whites).
 - ii. Silver Cloud granite shall be quarried, cut, and finished within 500 miles of the project site.
 - iii. The basis of design is Silver Cloud granite quarried in Lithonia, Georgia by Broad River Quarries which is located in Elberton, Georgia, 706-213-1255 or North Carolina Granite, Mt. Airy, North Carolina, 336-786-5141.
 - iv. Depending on the tile module selected for the space, the tile may be thin-set tiling or mortar-bed tiling.
 - v. The interior granite surface finish shall be honed with a clear penetrating sealer.
- D. Grout at restrooms and food service areas shall:
 - i. Use epoxy type grout meeting ANSI 118.3.
 - ii. Dark grout colors are preferred for floors.

3. EXECUTION

- A. For granite tile installation, the Contractor shall coordinate a pre-installation meeting with the Design Professional, Project Manager, and tile Subcontractor. It is understood that granite is a natural material and that color variation will occur; however, the Contractor and tile Subcontractor are responsible for the complimentary color and granite patterning distribution. Attention shall be given to the placement of matched tiles as directed by the Design Professional and Project Manager. The Contractor and tile Subcontractor shall avoid placing noticeably lighter Silver Cloud pieces in a field of darker Silver Cloud pieces and vice-versa. If this situation occurs without prior approval from the Project Manager, the Contractor shall remove and reinstall pieces as directed by the Project Manager at no additional cost to the Owner.



09 50 00
CEILINGS

1. GENERAL

- A. Related sections:
 - i. 09 00 00 – General Finishes Requirements
 - ii. 26 51 00 – Interior Lighting
- B. Ceilings and mechanical / electrical equipment coordination:
 - i. Mechanical and electrical access to equipment above a hard-lid ceiling requires a minimum of 24 inches x 24 inches access panel with clear path to the equipment.
 - ii. Coordination with mechanical, electrical, and plumbing equipment is required when laying out ceiling grids and supports; no mechanical, electrical, or plumbing access should be blocked
 - iii. A 'Maintenance Access' zone (vertically & horizontally) is to be defined and called out on drawings and maintained through final construction.
 - iv. Lighting shall not be located in the 'Maintenance Access' zones or access points.
 - v. Removal of ceiling tiles may not be blocked by equipment locations.
 - a. 6 inches from the suspended ceiling to the bottom of equipment & ductwork is required for ceiling tile removal.

2. PRODUCTS

- A. Concealed spline ceiling support systems are not allowed.
- B. 2' x 4' ceiling grid and tile not allowed.

3. EXECUTION

- A. Fiberglass batt insulation is not allowed to be placed directly on top of acoustical ceiling tiles.



09 60 00
FLOORING

1. GENERAL

A. Related sections:

- i. 01 35 46 – Indoor Air Quality Procedures – During Construction
- ii. 01 41 26.06 – Dining Services
- iii. 09 00 00 – General Finishes Requirements
- iv. 09 30 00 – Tiling
- v. 09 68 00 – Carpeting

2. PRODUCTS

- A. Low volatile organic compound (VOC) materials shall be used within the interior weatherproofing of the facility; zero when available. Refer to Section 01 35 46 Indoor Air Quality – During Construction.
- B. Regional Materials: For carpeting, refer to Section 09 68 00 Carpeting. All other flooring products shall have been extracted, harvested or recovered, as well as manufactured, within 500 miles of the project site for a minimum of 20%, based on cost, of the total materials value of flooring excluding carpeting. Provide documentation as requested by the Project Manager.
- C. Vinyl Composition Tile (VCT) shall contain a minimum 10% post-consumer recycled content or a minimum 5% post-consumer recycled content combined with a minimum 10% pre-consumer recycled content.
- D. **FMD Projects Only**
 - i. Epoxy flooring: For renovations with existing exposed concrete flooring in the auditorium, apply a two-component, high performance, polyamide-epoxy coating. Primer and finish coat shall be compatible and by the same manufacturer. Clean and prepare substrate according to manufacturer's specifications to ensure proper bonding.



09 68 00
CARPETING

1. GENERAL

- A. Related sections:
 - i. 01 35 46 – Indoor Air Quality Procedures – During Construction
 - ii. 01 74 19 – Construction Waste Management and Disposal
 - iii. 09 00 00 – General Finishes Requirements
 - iv. 12 48 26 – Entrance Carpet Tile
- B. Any existing carpeting that is removed must be recycled per Section 01 74 19 Construction Waste Management and Disposal.
- C. As part of the submittals, provide flame spread documentation demonstrating compliance of carpets with code requirements. State the minimum requirements per the applicable codes and the flame spread of the products.
- D. Carpeting is prohibited in telecommunications MDF / IDF rooms.

2. PRODUCTS

- A. Low volatile organic compound (VOC) materials shall be used within the interior weatherproofing of the facility; zero when available. Refer to Section 01 35 46 Indoor Air Quality – During Construction.
- B. Regional Materials: Provide carpets that have been manufactured within the state of Georgia. Provide documentation as requested by Project Manager.
- C. Use only carpet and carpet cushion that meets or exceeds requirements of Green Label Plus, set by the Carpet and Rug Institute.
- D. Any carpet cushion shall be an attached backing system to the carpet and not a separate underlayment system.
- E. The Design Professional shall forward manufacturer's suggested carpet maintenance cleaning methods to the Project Manager for review and approval.
- F. Minimum 10-year manufacturer's warranty covering: wear, edge ravel, tuft bind, delamination, and static control.
- G. Requirements for carpeting attic stock shall be coordinated with the Project Manager.



09 72 00
WALL COVERINGS

1. **GENERAL**
 - A. Wall coverings are a long-term maintenance issue.
2. **PRODUCTS**
 - A. Vinyl coated fabric wall coverings, flexible vinyl wall coverings, rigid sheet vinyl wall coverings, and wallpaper are not allowed. Wall coverings are occasionally allowed as specialty accents, but must be approved through the variance process.
 - B. Textile wall coverings are not allowed unless they are part of an acoustical wall treatment system approved by the Project Manager.



09 80 00
ACOUSTICAL TREATMENT

1. GENERAL

A. Related sections:

- i. 00 00 13 – Designing Learning Environments
- ii. 09 00 00 – General Finishes Requirements
- iii. 12 05 13 – Fabrics

2. PRODUCTS

- A. Low volatile organic compound (VOC) materials shall be used within the interior weatherproofing of the facility; zero when available. Refer to Section 01 35 46 Indoor Air Quality – During Construction.
- B. As part of the submittals, provide flame spread documentation demonstrating compliance of the acoustical treatment assembly with code requirements. State the minimum requirements per the applicable codes and the flame spread of the products and assembly.



09 91 23
INTERIOR PAINTING

1. GENERAL

- A. Related sections:
 - i. 01 32 16 – Construction Progress Schedule
 - ii. 01 35 46 – Indoor Air Quality Procedures – During Construction
- B. In addition to card stock brush-outs, Contractor shall provide 6'x6' in place samples for each paint color, with final light fixtures and lamps in place, as requested by the Design Professional and / or Project Manager as part of the Cost of the Work or Bid.

2. PRODUCTS

- A. Low volatile organic compound (VOC) materials shall be used within the interior weatherproofing of the facility; zero when available. Refer to Section 01 35 46 Indoor Air Quality – During Construction.
- B. All coatings shall be commercial grade.
- C. Acceptable Manufacturers:
 - i. Benjamin Moore Company
 - ii. PPG Paints
 - iii. Sherwin-Williams Company
- D. Paint Sheens
 - i. Painted walls shall have eggshell paint sheen.
 - ii. Painted wood trim shall have semi-gloss sheen.
 - iii. Flat paint sheen is prohibited on walls and trim.