



33 00 00
GENERAL UTILITIES REQUIREMENTS

1. GENERAL

- A. Related sections:
 - i. 01 41 26.02 – Local Utility Information & Locate
 - ii. 23 05 19 – Meters and Gauges
 - iii. 32 12 16 – Asphalt Paving
 - iv. 33 10 00 – Water Utilities – Public Water Distribution System 33 12 13.13 – Water Supply Backflow Preventer Assemblies
 - v. 33 30 00 – Sanitary Sewerage Utilities – Sanitary Sewer Collection Systems
 - vi. 33 60 00 – Hydronic and Steam Energy Utilities
 - vii. 33 71 19 – Electrical Underground Ducts & Manholes
 - viii. 33 80 00 – Communications Utilities
- B. Contractor shall install and make operational the applicable utility revenue meter(s) and notify FMD Utility and Energy Management prior to using any utility where UGA is the utility provider. Any un-metered utility use will be estimated by UGA based on the peak design usage rate applied over the period in which un-metered usage begins until the utility revenue meter is fully functional and FMD UEM is notified.
- C. Accessible isolation valves, identified as to function, shall be provided at all new taps from existing utilities.
- D. Utility Detection Wire/Tape:
 - i. For all underground utilities, a tracer wire of copper, copper clad steel, or stainless steel shall be installed. Wire shall be 12 awg or larger, coated with 45 mil or larger HDPE sheathing, and APWA color coded. The tracer wire should be placed on the bed of the trench, ditch, under the utility, and must be grounded via a ground rod at each end of the main runs.
 - ii. In addition to tracer wire, provide detectable aluminum foil plastic backed tape or detectable magnetic plastic tape manufactured specifically for warning and identification of buried utility. Tape shall be APWA color coded.
- E. Existing services and equipment shall be specified to be removed from site and not be abandoned in place except with the written approval of FMD.
- F. The Contractor shall adjust all existing and new utility structures (manholes, valve boxes, etc.) to meet new grades as required to complete this project at part of the Cost of the Work or Base Bid.
- G. The Engineer shall provide underground profile drawings of all utilities to be installed on campus (steam, chilled water, electrical duct bank, sewer, storm, etc.) clearly indicating depths of existing underground utilities.
- H. Where utility excavation will be required, the Engineer shall specify “maximum limits of excavation” and shall calculate anticipated rock and unsuitable soil allowances. In addition, the engineer shall specify that the contractor provide “unit prices” for rock, and unsuitable soils.
- I. Design Professional shall provide spot elevations for hardscape and landscape elements as required to clearly illustrate storm water flow direction.
- J. Design Professional shall route all utilities to avoid the critical root zone of mature trees and landscapes. When absolutely necessary to enter the critical root zone of mature

*Revised July
30, 2024*

*Revised July
30, 2024*



trees a licensed arborist must be consulted to determine the best course of action for attempting to preserve the tree.

- K. Design Professional shall include pedestrian re-routing plans and traffic control drawings where applicable.
- L. Underground utilities, to include electrical duct-bank, communications conduit, or any other conduit that can be damaged by high temperatures shall be protected at steam pipe crossings (in the case of steam piping failure or insulation failure) in the immediate vicinity (within 36 inches). The protection shall consist of both thermal and physical barriers utilizing a minimum of 12-inch thick Gilsulate (or equal) and a physical barrier (3/8-inch thick, 316 grade stainless steel plate). The protection shall extend a minimum 12 inches in every direction beyond the crossing of the steam line.
- M. All modified or new sanitary and storm mains shall be camera-ed at the end of the project and the video submitted as part of the close-out documents.



33 10 00

WATER UTILITIES – PUBLIC WATER DISTRIBUTION SYSTEM

1. GENERAL

A. Related sections:

- i. 01 41 26.02 – Local Utility Information & Locate



33 12 13.13
WATER SUPPLY BACKFLOW PREVENTER ASSEMBLIES

1. GENERAL

- A. Related sections:
 - i. 01 41 26.02 – Local Utility Information & Locate
- B. Building backflow preventers shall be designed and installed so that two backflow preventers are in parallel. This will allow for annual maintenance to occur without disruption of service.
- C. RPZ backflow preventer drain sizes shall be a minimum of 2.5x the supply line size and shall also be required to include a flood control valve to prevent flooding in the event of catastrophic failure.

*Revised July
30, 2024*



33 30 00

SANITARY SEWERAGE UTILITIES – SANITARY SEWER COLLECTION SYSTEM

1. GENERAL

- A. Related sections:
 - i. 01 41 26.02 – Local Utility Information & Locate
- B. Prior to Material Completion, the Contractor shall camera all new sanitary sewer pipe installed exterior to the building perimeter, and 10 feet beyond the connection point with existing pipe. The Contractor shall provide the Design Professional and Project Manager with an electronic copy of the video footage for review. Cost of videoing the system shall be included in the Cost of the Work or Base Bid.
- C. Sanitary sewer piping shall be installed in a 6-inch minimum sand bed if piping is PVC. A gravel bed is acceptable for other piping materials.
- D. Schedule 40 PVC is acceptable for use under concrete slabs.
- E. Acid neutralization tanks are not needed. It is not required by USG Design Criteria for Laboratories (2019) and the UGA Research Safety Committee determined that general UGA guidance and other administrative controls could mitigate the need for them.

*Revised July
30, 2024*



33 42 00
DOWNSPOUT CONVEYANCE PIPES

1. GENERAL

- A. Related sections:
 - i. 33 00 00 – General Utilities Requirements
- B. This section describes the requirements for storm drainage systems, including piping and all necessary accessories as designated in this section.

2. PRODUCTS

- A. See accompanying typical details at the end of this section.
- B. PVC storm sewer pipe and fittings shall be 6" minimum schedule 40 solid core piping conforming to ASTM D1785 and ASTM D2665, Sewer and Drain Series, with ends for solvent cemented joints.
- C. PVC joints shall be solvent welded socket type using solvent cement conforming to ASTM D2564 and adhesive primer conforming to ASTM F656. Bio-based materials shall be utilized when possible.
- D. Cleanouts
 - i. Downspout cleanouts shall be required on all downspouts. Cleanouts shall be easily accessible and shall be watertight.
 - ii. Each downspout shall be converted to round pipe, with proper adapter, upstream of clean out.
 - iii. Clean out shall be a wye fitting to match size of downspout; not less than 6 inches in diameter.
 - iv. A minimum clearance of 24 inches shall be provided for clearing a clogged storm sewer line.
 - v. Clean out shall be between 24" and 6" above finished grade.

3. EXECUTION

- A. The pipe installation shall comply with the requirements of these specifications and the current edition of the International Plumbing Code adopted in Georgia at the time of design.
- B. All pipe runs shall be laid out to avoid interference with other work/trades.
- C. Pipe shall be round and straight. Cutting shall be done with proper tools. Pipe, except for glass, shall be reamed to remove burrs and a clean smooth finish restored to full pipe inside diameter.
- D. The piping shall be installed free of sags.
- E. Unless otherwise stated on the documents, minimum horizontal slope shall be two inches for every 8 feet: 2 percent slope.
- F. Buried storm drainage piping shall be laid beginning at the low point of each system. Piping shall be installed true to grades and alignment indicated with unbroken continuity of invert. Hub ends shall be placed upstream. Required gaskets shall be installed according to manufacturer's written instruction for use of lubricants, cements, and other installation requirements. Bio-based materials shall be utilized when possible.
- G. Changes in direction for storm drainage piping shall be made using appropriate branches, bends and long sweep bends. Do not change direction of flow more than 90 degrees. Proper size of standard increaser and reducers shall be used if pipes of



- different sizes are connected. Reducing size of drainage piping in direction of flow is prohibited.
- H. When elevations allow, all pipes shall be buried below the frost line and have minimum of 18" cover.

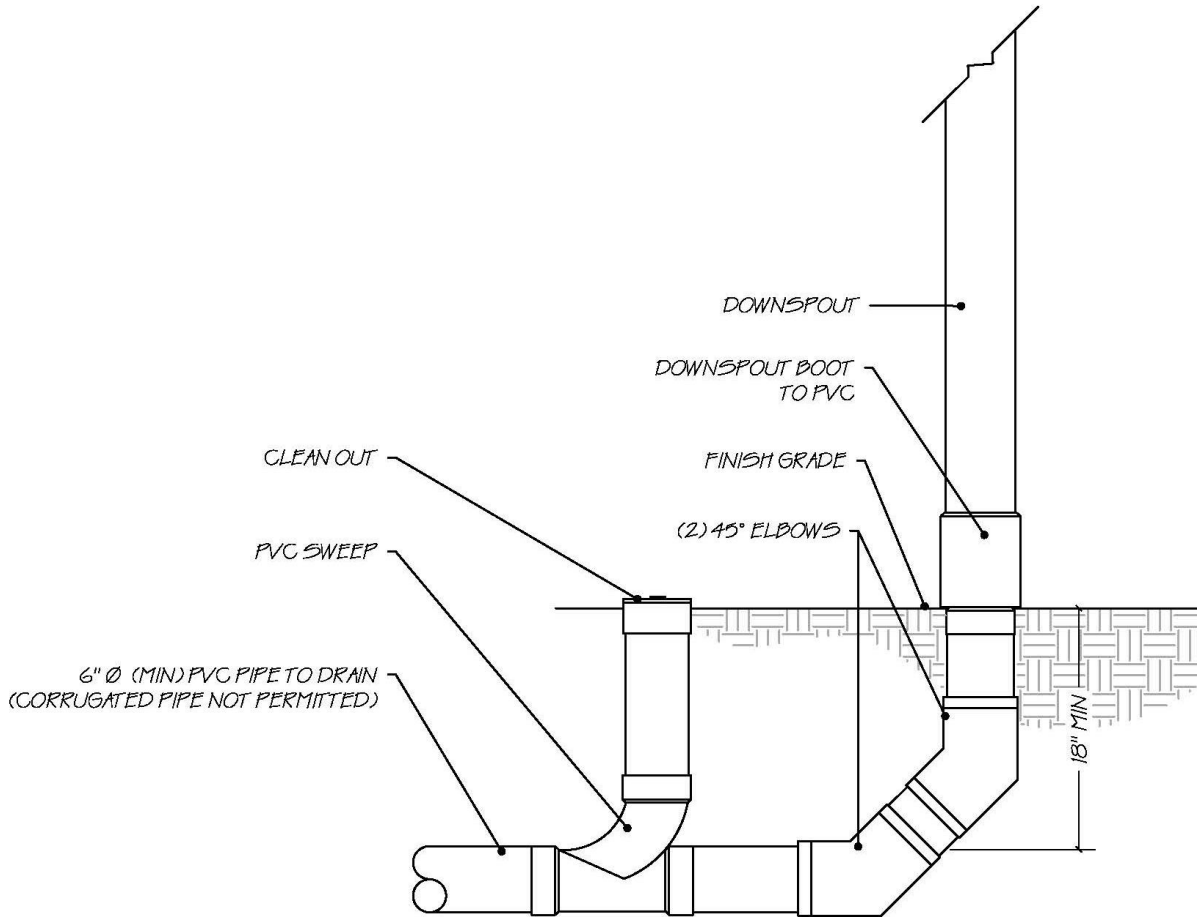

○ TYPICAL BUILDING DRAIN W/ CLEAN OUT DETAIL
NOT TO SCALE

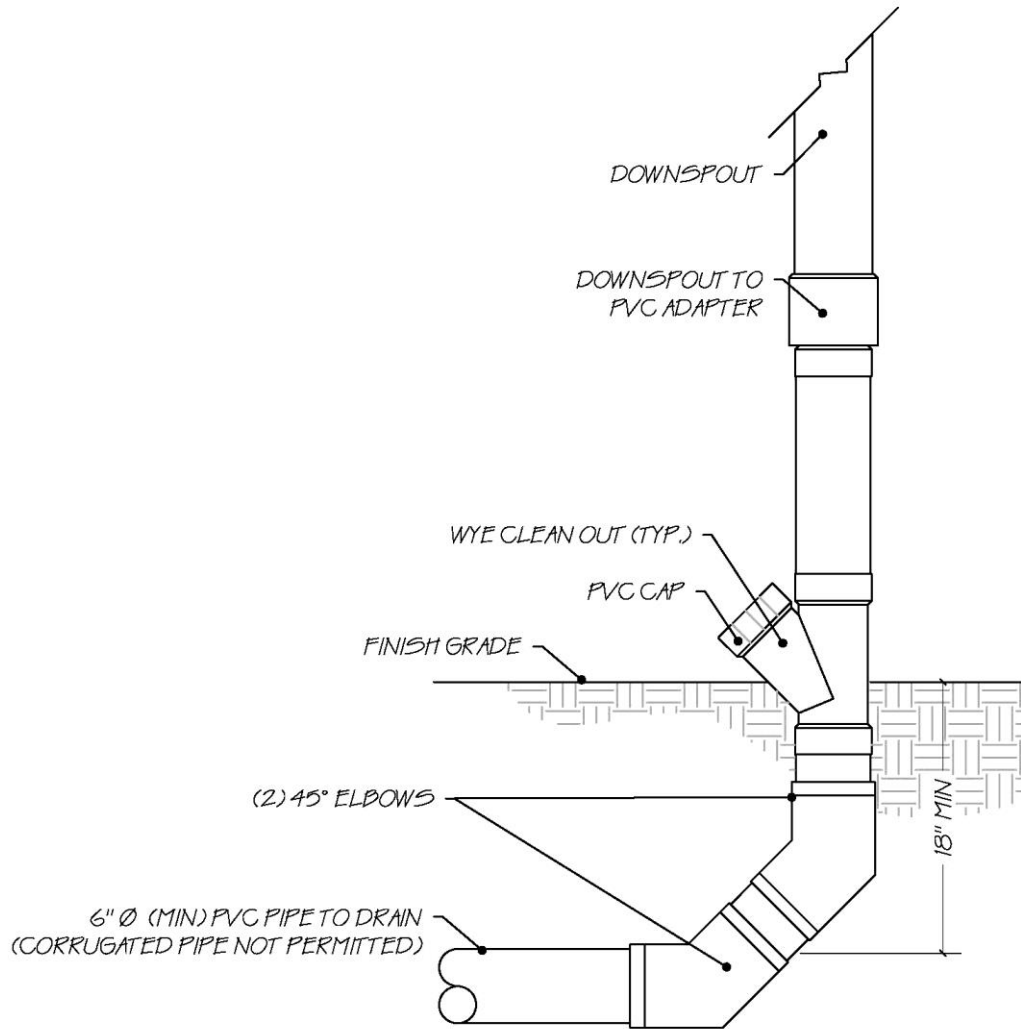

 TYPICAL DOWNSPOUT CLEAN-OUT DETAIL
NOT TO SCALE



33 60 00
HYDRONIC AND STEAM ENERGY UTILITIES

1. GENERAL

- A. Related sections:
 - i. 23 00 00 – General Mechanical Requirements
 - ii. 23 21 13 – Hydronic Piping
 - iii. 23 22 13 – Steam & Condensate Heating Piping
 - iv. 33 00 00 – General Utilities Requirements
- B. Design Professional shall specify fiber reinforced polymer composite, traffic rated, secure locking lids for heavy electrical manhole covers. New cast iron covers will not be accepted.

2. PRODUCTS

- A. “Pre-cast” can be considered if the following conditions are met. This is a response to cost concerns.
 - i. Vault structure shall withstand H-20 Loading.
 - ii. Contractor shall submit stamped shop drawings provided by registered (in the state of the project) structural engineer for review.
 - iii. Contractor shall over-excavate for vault and install 12” of No. 57 stone under pre-cast vault.
- B. Vaults shall be cast-in-place (if applicable), reinforced concrete construction and shall be water-proofed (top, bottom and sides) with a sheet membrane system that bonds to the concrete.
 - i. For steam vaults, refer to Appendix A for UGA Steam Vault Standard Detail
- C. Pipe penetrations shall be sleeved and the space between the piping outer jacket and the sleeve shall be sealed with link-seal, and the void filled with non-shrinking grout.
- D. Vaults shall be provided with sump pumps.
 - i. Chilled water vault sumps shall be electric.
 - ii. Steam vault sumps shall be steam-powered.
- E. Steam manhole cover.
 - i. Cast iron construction with load rating appropriate for location.
 - ii. Molded with “STEAM” inscription.
 - iii. For vaults located in softscape, steel vented tops with hinged door access is preferred. Where located under hardscape, provide steel manhole cover. Discuss with Project Manager.
- F. Chilled Water manhole cover equal to Virtual Polymer Compounds, LLC (VPC) manhole cover with penta-socket bolt head lock(s).
 - i. H-20 and AASHTO HS-25 load rating for 80,000 lb.
 - ii. Self-containing locking system that provides cover to frame retention and security from unauthorized entry and uses a penta-socket bolt head.
 - iii. Fiber reinforced polymer
 - iv. Egress handle:
 - a. Provide a manual pull handle for use by individual inside the manhole a means to exit



- b. All plastic construction to resist corrosion, parts molded in high visibility yellow
- c. Pulling the handle will latch open one of the cartridge assemblies and allow the person to push the cover out of the frame and then exit.
- v. Ultraviolet radiation will not affect long term performance of composite manhole cover.
- vi. Logo Plate: Stainless Steel plate 1/8-inch thick that as appropriate says "CHILLED WATER".
- vii. All metallic hardware shall be 316 stainless steel.

3. EXECUTION

- A. Contractors shall coordinate with FMD Welding Shop (706-542-7593) before entering steam pits.
- B. Vaults sump pumps shall be piped to the nearest storm manhole.



33 71 19

ELECTRICAL UNDERGROUND DUCTS & MANHOLES

1. GENERAL

- A. Related sections:
 - i. 26 00 00 – General Electrical Requirements
 - ii. 33 00 00 – General Utilities Requirements
- B. Design Professional shall specify fiber reinforced polymer composite, traffic rated, secure locking lids for heavy electrical manhole covers. New cast iron covers will not be accepted.

2. PRODUCTS

- A. Electrical manhole / handhole cover equal to Virtual Polymer Compounds, LLC (VPC) manhole cover with penta-socket bolt head lock(s).
 - i. H-20 and AASHTO HS-25 load rating for 80,000 lb.
 - ii. Self-containing locking system that provides cover to frame retention and security from unauthorized entry and uses a penta-socket bolt head.
 - iii. Fiber reinforced polymer.
 - iv. Egress handle:
 - a. Provide a manual pull handle for use by individual inside the manhole a means to exit.
 - b. All plastic construction to resist corrosion, parts molded in high visibility yellow.
 - c. Pulling the handle will latch open one of the cartridge assemblies and allow the person to push the cover out of the frame and then exit.
 - v. Ultraviolet radiation will not affect long term performance of composite manhole cover.
 - vi. Logo Plate: Stainless Steel plate 1/8-inch thick that as appropriate says "ELECTRIC" or "HIGH VOLTAGE".
 - vii. All metallic hardware shall be 316 grade stainless steel.
- B. Manhole / Handhole Cable Racking
 - i. Underground Devices Incorporated "BNT Non-Metallic Cable Support" system with 316 grade stainless steel stanchion hardware, or approved equal.
- C. Refer to schematic drawings at end of this section.

3. EXECUTION/INSTALLATION

- A. All conduits entering/leaving manholes shall be straight for a minimum of 5'-0" (no bends) off of the exterior walls of the manhole / handhole, and there shall be no conduit elbows into or out of manholes / handholes.
- B. Leave a minimum of 1'-0" of conduit extending into manhole when using cored holes.



SCHMATIC DRAWINGS FOR GENERAL REFERENCE ONLY

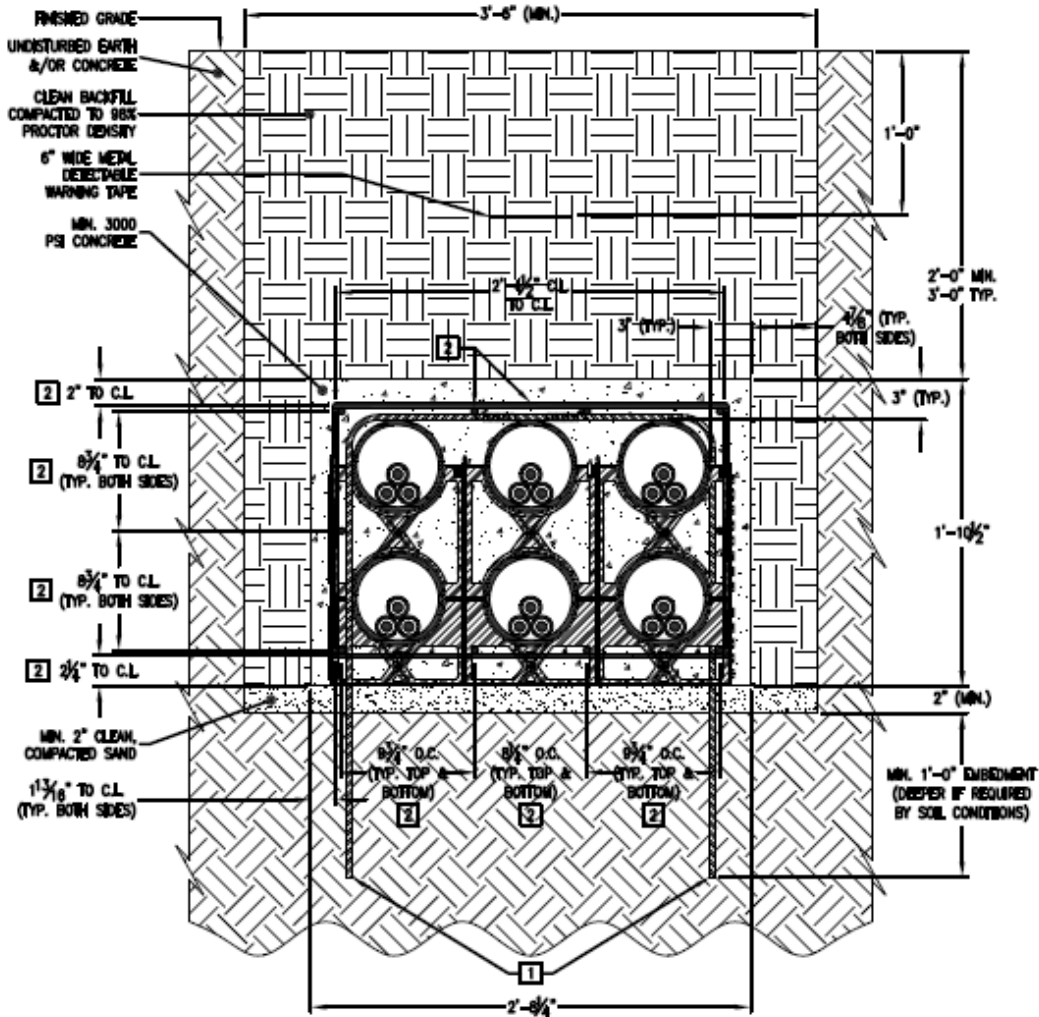

GENERAL NOTES:

- 6" SCH 40 PVC CONDUITS ARE SPACED 9-3/4" O.C. PROVIDING 3" OF CONCRETE SEPARATION BETWEEN EACH ONE.
- THIS DETAIL USES INTERLOCKING 'CANTEX' PART #5338040 BASE SPACERS & PART #5338041 INTERMEDIATE SPACERS WHICH SHALL BE SPACED 5'-0" O.C., HORIZONTALLY ALONG THE LENGTH OF THE DUCT BANK. IF OTHER CONDUIT SPACERS ARE SPECIFIED, ENSURE THEY COMPLY WITH GENERAL NOTE #1.

KEY NOTES: [1]

- PROVIDE & INSTALL (2) 90° #3 GALVANIZED, STEEL RE-BARS AT EACH SET OF SPACERS (5'-0" O.C.) TO PREVENT CONDUIT FLOATING WHILE CONCRETE IS POURED. ALLOW MINIMUM 8" TOTAL OVERLAP AT TOP CENTER AND WIRE TIGHTLY TOGETHER. ROUTE DOWN AND THROUGH SPACER HOLES ON OPPOSING SIDES OF SPACERS WITH MINIMUM EARTH EMBEDMENT OF 12". SOIL CONDITIONS MAY DICTATE DEEPER EMBEDMENT. IF ROCK IS ENCOUNTERED, EMBED RE-BARS MINIMUM 12" INTO EARTH (DEEPER IF SOIL CONDITIONS REQUIRE) AT A MAXIMUM ANGLE OF 45° INTO SIDE(S) OF EXCAVATION.
- PROVIDE & INSTALL (10) #5 RE-BARS LONGITUDINALLY AS DIMENSIONED IN DRAWING, AND #4 RE-BAR LATERAL 'RINGS' AT 18" O.C. LONGITUDINALLY FOR ANY DUCT BANK SECTIONS BENEATH ANY ROADS OR TRAFFIC RATED AREAS. EXTEND STEEL REINFORCING TO MINIMUM 10'-0" BEYOND ROAD SHOULDERS OR TRAFFIC RATED AREAS. USE CHAIRS OR BRICKS TO SUPPORT RE-BAR OFF OF SAND. THE 'PULL-UP' OR 'PUSH-DOWN' METHODS FOR POSITIONING RE-BARS AFTER CONCRETE IS POURED ARE NOT ALLOWED.

1 TYPICAL 3x2, 6'Ø CONDUIT PRIMARY CONCRETE DUCT BANK
E-7 SCALE: NONE



SCHEMATIC DRAWINGS FOR GENERAL REFERENCE ONLY

GENERAL MANHOLE DETAILS:

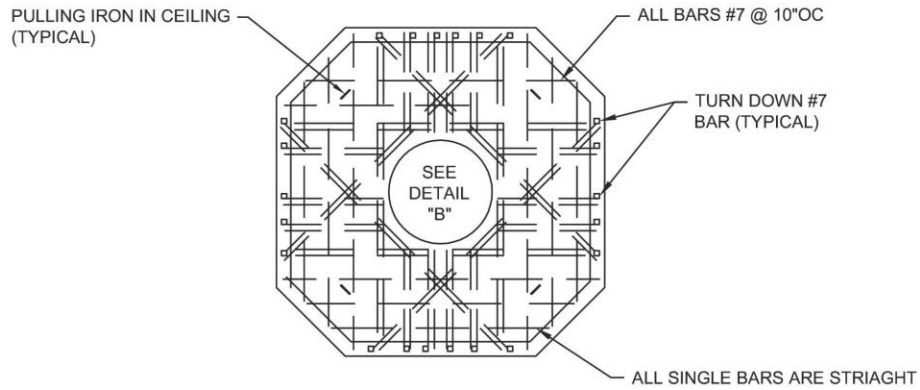

ROOF PLAN
NTS

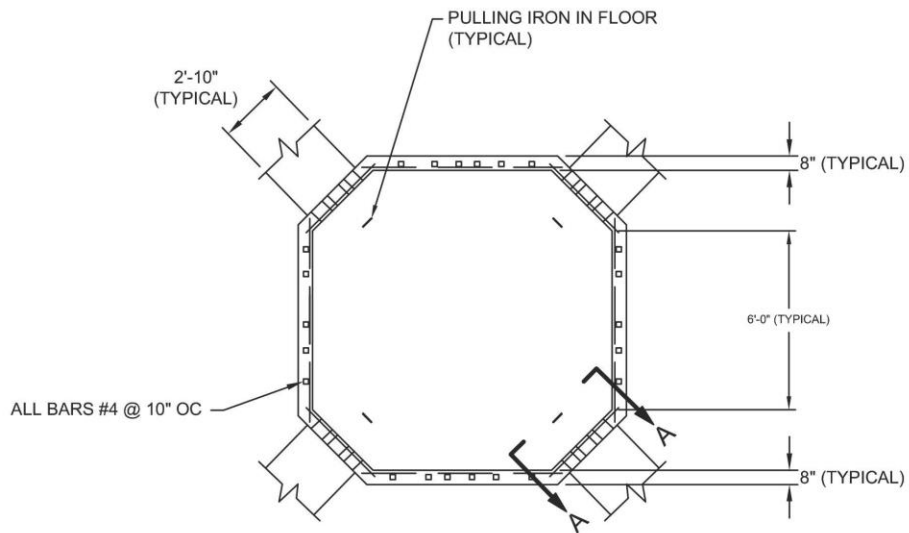

PLAN BELOW ROOF
NTS



SCHEMATIC DRAWINGS FOR GENERAL REFERENCE ONLY

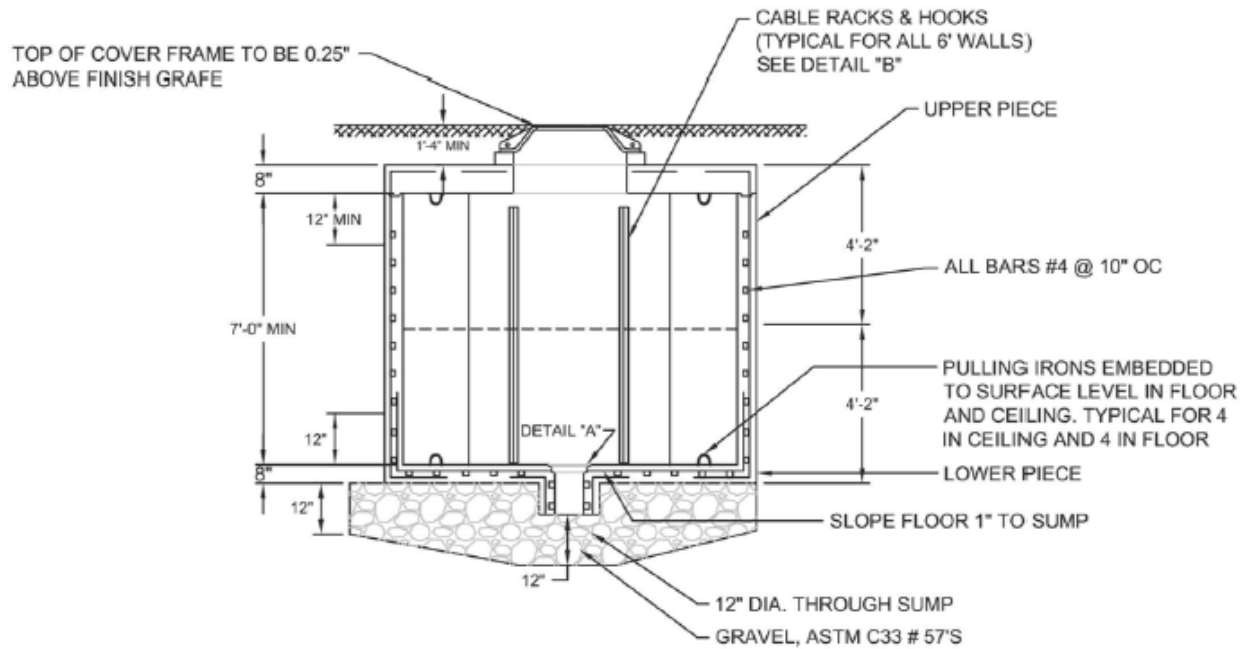

ELEVATION

NTS

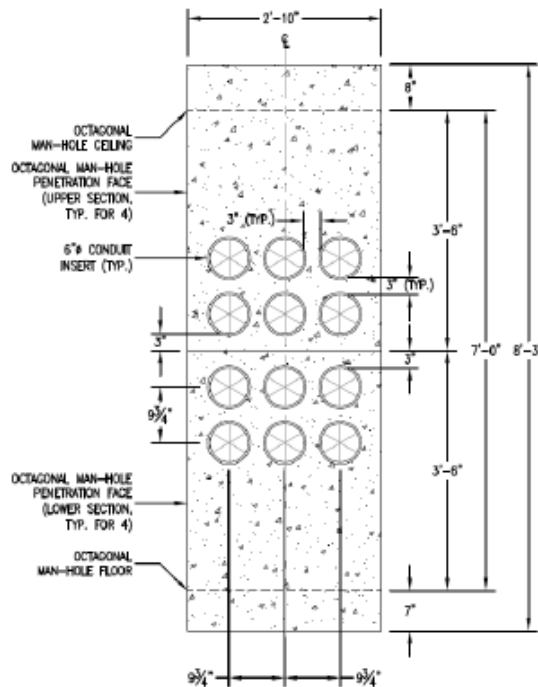

SECTION A-A (TYPICAL 4 SIDES)

NTS



SCHEMATIC DRAWINGS FOR GENERAL REFERENCE ONLY

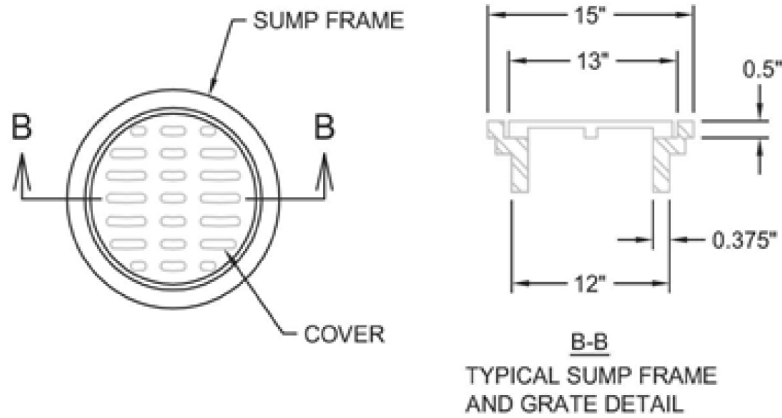

DETAIL A – SUMP COVER
NTS

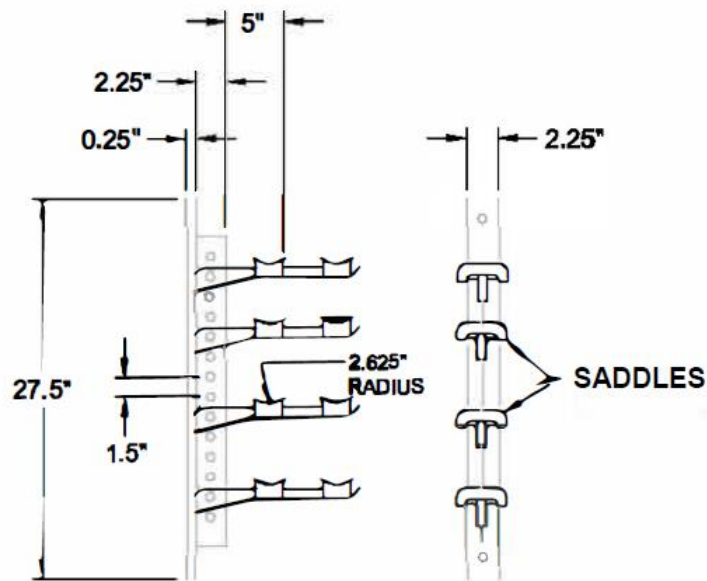

**NOTE: FASTEN BY MEANS OF 2.5" X 0.5"
BOLTS AND EXPANSION SHIELDS**

DETAIL B – CABLE RACKING
NTS



33 80 00
COMMUNICATIONS UTILITIES

1. **GENERAL**

A. Related sections:

- i. 27 00 00 – General Communications Requirements
- ii. 27 05 43 – Underground Ducts & Raceways for Communications